



Produits > Congélateurs coffre > Porte coulissante en verre (FG)> FG 1600 .450Litres



Modèle: FG 1600 .450 litres
Couleur: blanc

Volume: 450 litres

Deux portes coulissantes en verre

Caractéristiques:

- Thermostat réglable
- Compresseur de qualité tropicale
- Charge de gaz: R290 ou R404a
- Ventilateur sur le compresseur
- Sans CFC-220/240
- V 50/60 HZ
- Quatre roues robustes rotatives avec freins
- Environnementales amical
- CE, TUV, SASO, GS, IRI, ROHS APPROUVÉ

Spécifications techniques :

Volume: 450 Litres
(LxPxH) 133x66x93 cm

Poids brut (kg): 76
Conteneur Qty./20ft: Conteneur 24
Qty./40ft: Conteneur 50
Qty./40ft(HC): 66

Caractéristiques optionnelles :



Dimensions:

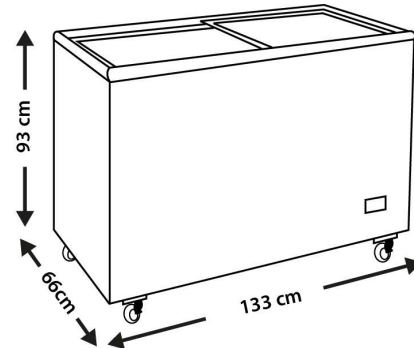

Stay Updated to our
LATEST NEWS & Offers

Email in here...

SUBSCRIBE



Do you have any Questions?!

[Click here to ask](#)